

- ✓ OPTIMAL POSITION of the axis of the chamber which guarantees a minimum loss of load and reducing the effect of cavitation.
- ✓ Rigid closing of the piston which provides GREAT ACCURACY in the control regulation.
- ✓ Spring cylindrical base to achieve a HIGH LEVEL OF PRECISION in the operation.
- ✓ The valve can work as SIMPLE OR DOUBLE CHAMBER.
- ✓ ONLY SUITABLE FOR AGRICULTURAL USE

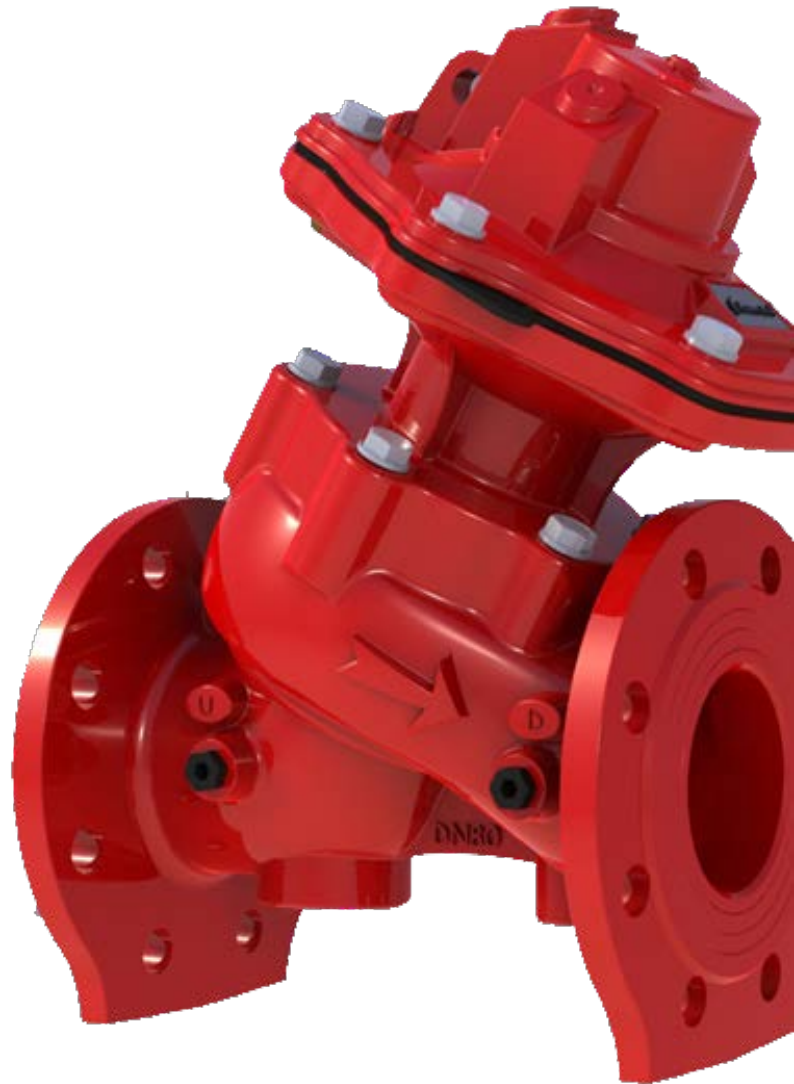
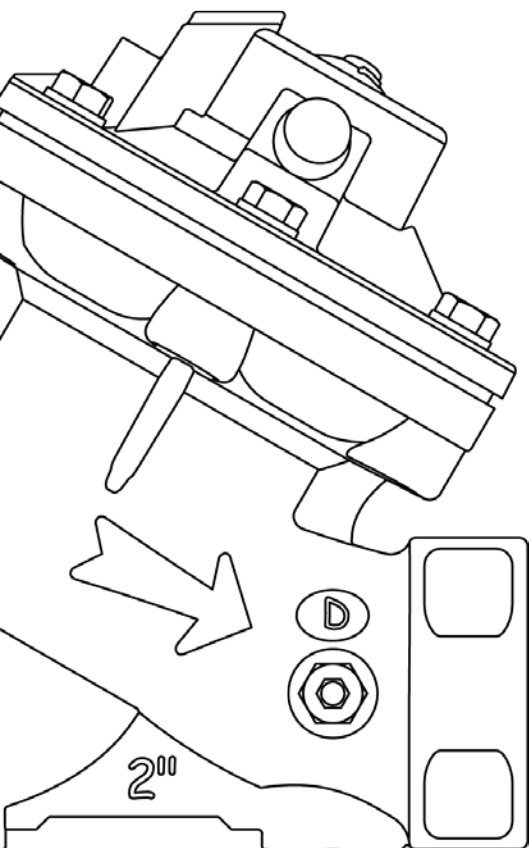

SPECIFICATIONS

- CONNECTIONS : 2" _DN50: Threaded BSP, NPT;
3" _DN80: Flanged ISO, ANSI, BS.
- DESIGN: Single or double chamber line design.
- SIZES RANGE :
Thread: 2"-DN50
Flange: 3" – DN80.
- NOMINAL PRESSURE (bar): PN16.
(psi): PN232.

MATERIALS

- BODY AND COVER: GGG-40 Ductile Iron.
- DIAPHRAGM: Natural rubber reinforced with nylon.
- SPRING: Stainless steel.
- COVERING: Epoxy-polyester double covering.

SIMPLE CHAMBER

- P1 = Upstream pressure
- P2 = Downstream pressure
- P3 = Control chamber pressure
- P4 = Double chamber pressure
- A = Double chamber access
- B = Double chamber plug
- SD = Closing disc surface
- SM = Diaphragm surface (SM=3SD)
- FM= Spring force
- FR= Axis friction force

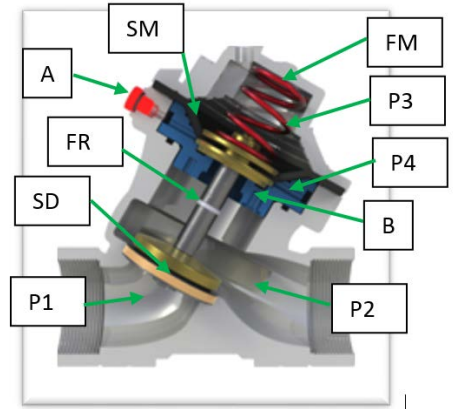

OPENING FORCE (FA)

$$FA = P1 \cdot SD + P4 \cdot SM$$

OPENING \rightarrow $FA > FC + FM$

$$P3 = 0, P4 = P2$$

$$P1 \cdot SD + P4 \cdot SM > P2 \cdot SD + FM$$

CLOSING FORCE (FC)

$$FC = P2 \cdot SD + P3 \cdot SM + FM$$

CLOSING \rightarrow $FA < FC$

$$P3 = P1, P4 = P2 = 0$$

$$P1 \cdot SD + P4 \cdot SM < P2 \cdot SD + P3 \cdot SM + FM$$

$$P1 \cdot SD < P3 \cdot SM + FM$$

DOUBLE CHAMBER

- P1 = Upstream pressure
- P2 = Downstream pressure
- P3 = Control chamber pressure
- P4 = Double chamber pressure
- A = Double chamber access
- B = Double chamber cup
- SD = Closing disc surface
- SM = Diaphragm surface (SM=3SD)
- FR= Axis friction force

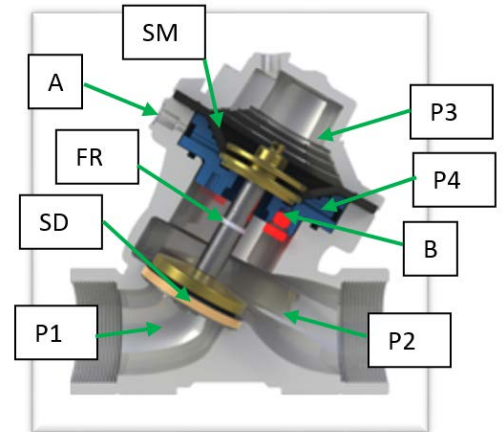

OPENING FORCE (FA)

$$FA = P1 \cdot SD$$

$$FA = P1 \cdot SD + P4 \cdot SM \Leftrightarrow P1=P4$$

It is necessary to activate the double chamber for a full opening and deactivate it for closing.

OPENING \rightarrow $FA > FC$

$$P3 = 0, P1=P4$$

$$P1 \cdot SD > P2 \cdot SD \quad P1 \cdot SD + P4 \cdot SM > P2 \cdot SD$$

FUERZA CIERRE (FC)

$$FC = P2 \cdot SD + P3 \cdot SM$$

CLOSING \rightarrow $FA < FC$

$$P3 = P1, P4 = P2 = 0$$

$$P1 \cdot SD < P2 \cdot SD + P3 \cdot SM$$

COMETAL hydraulic valves comply with the specifications of the standards **UNE - EN 1074** about valves for the supply of water and **ISO 9635** about irrigation valves with reference to **general requirements, mechanical resistance and watertightness**.



COMPONENTS
BODY, COVER AND PLATFORM
BOLTS
DIAPHRAGM
SPRING
PISTON AXIS
JOINTS
O-RINGS
OTHER INNER PIECES

DIMENSIONS AND WEIGHTS

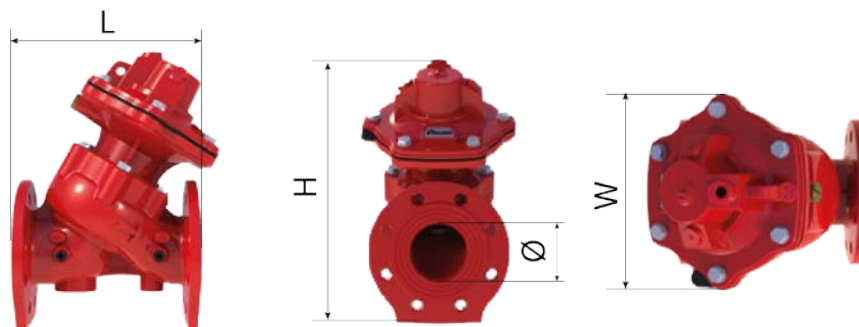

MODEL	CONNECTION	LENGTH (L)		HEIGHT (H)		INSIDE DIAM (ø)	WIDTH (W)		WEIGHT Kg
		mm	inch	mm	inch	inch	mm	inch	
2"	THREAD	186	7.32	198	7.79	2"	147,3	5.79	7.4
DN80	FLENAGE	252	9.92	377,6	14.86	3"	229,1	9.01	25.9

DCP VALVES

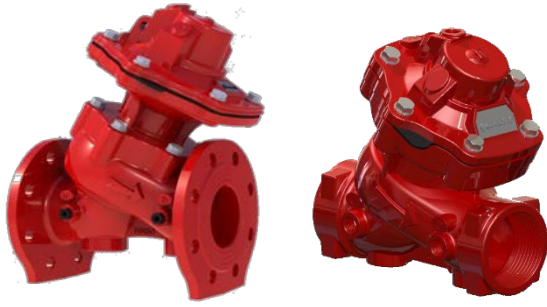

COMETAL valves comply with the following standards for threaded connections:
BSP. 7.1 ISO - 228.1 ISO - UNE - EN 10226 - BS-EN 10226. ISO standard and European standards.
NPT. ASME-ANSI B 1.20. American standard.

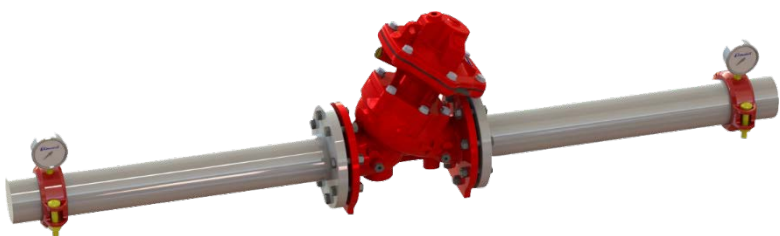
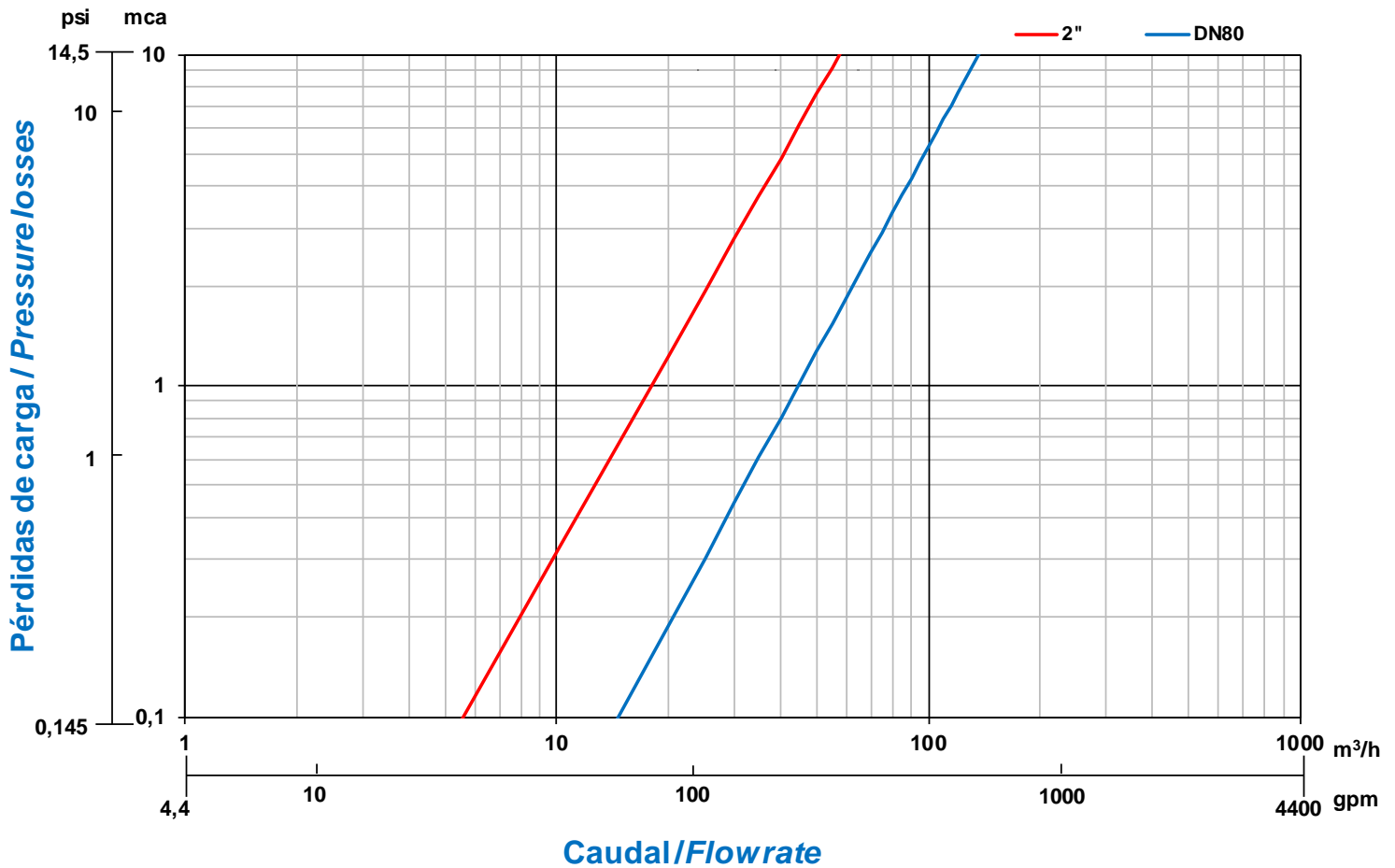

Friction Head Loss is measured from A to B

COMETAL hydraulic valves comply with the specifications of the standards **UNE-EN 1267** and **ISO 9644** in terms of friction head loss tests.

MODEL	CONNECTION	KV		CONTROL CHAMBER VOLUME
		m3/h	gpm	litres
2"	THREAD	58	255.4	0,10
DN80	FLANGE	135	594.4	0,43